

CHAPTER THIRTEEN

NETWORK ANALYSIS

Specific objectives

At the end of this topic the trainee should be able to:

- ❖ Describe networks and need for the analysis;
- ❖ Construct project networks;
- ❖ Determine the critical path;
- ❖ Apply network analysis to decision problems.

INTRODUCTION

This is a system of interrelationship between jobs and tasks for planning and control of resources of a project by identifying critical path of the project.

Terminology

Activity. Task or job of work, which takes time and resources e.g building a bridge. It is represented by an arrow which indicates where the task begins and ends



Event (node). This is a point in time and it indicates the start or finish of an activity e.g in building a bridge, rails installed. It is represented by a circle.



Dummy activity. An activity that doesn't consume time or resources, it is merely to show logical dependencies between activities so as abide by rules of drawing a network, it is represented by a dotted arrow

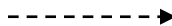

Network. This is a combination of activities and events (including dummy activities)

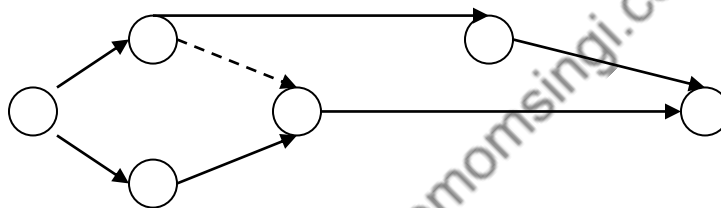

Rules for Drawing a Network

- A network should only have one start point and one finish point (*start event and finish event*)
- All activities must have at least one preceding event (*tail event*) and at least one succeeding event (*head event*), but an activity may not share the same tail event and head event.
- An activity can only start after its tail event has been reached
- An event is only complete after all activities leading to it are complete.
- Activities are identified by alphabetical or numeric codes i.e. A,B,C; 1,2,3 or identification by head or tail events 1-2, 2-4, 3-4,1-4...
- Loops (a series of activities leading back to the same event) and dangles (activities which do not link to the overall project) are not allowed

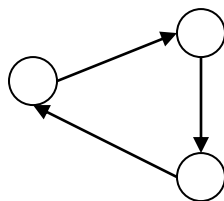

Loop

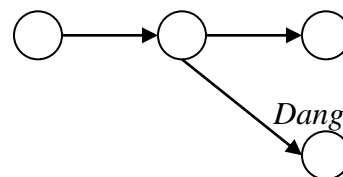

Dangling activity

Dummy Events

This is an event that does not consume time or resources, it is represented by dotted arrow. Dummies are applied when two or more events occur concurrently and they share the same head and tail events e.g. when a car

goes to a garage tires are changed and break pads as well, instead of representing this as;

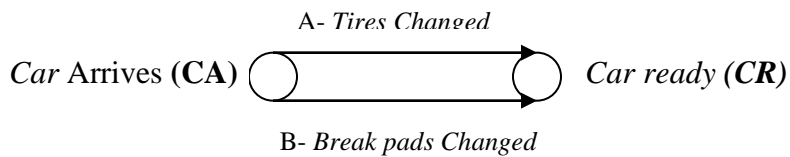

These events are represented as;

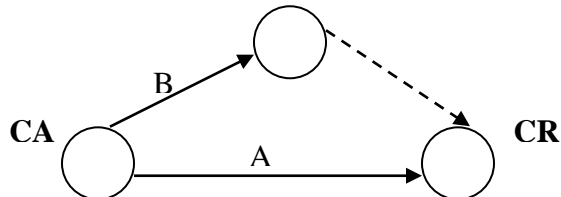

Example of a network.

Activities

1-2 - where 1 is the preceding event where as 2 is the succeeding event of the activity

1-3

2-4

2-5

3-5

4-5

4-6

5-6

6-6

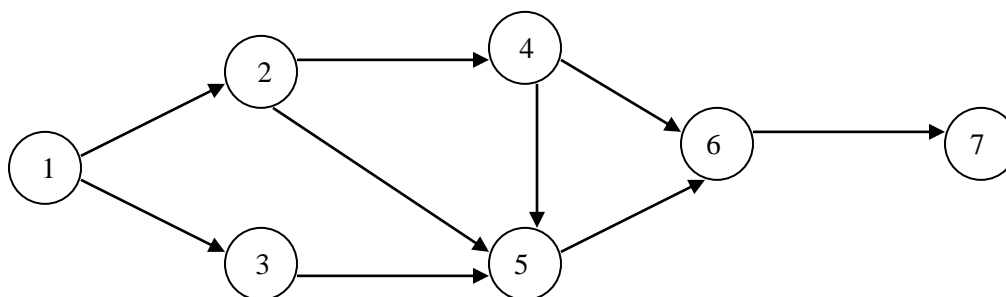

Network Analysis-Time Analysis

Assessing the time

- a) After drawing the outline of the network time durations of the activities are then inserted.
- a) Time estimates. The analysis of the projects time can be achieved by using :

- i. Single time estimates for each activity. These estimates would be based on the judgment of the individual responsible or by technical calculations using data from similar projects
- ii. Multiple time estimates for each activity. the most usual multiple time estimates are three estimates for each activity , i.e. optimistic (O), Most Likely (ML), and Pessimistic (P). These three estimates are combined to give an expected time and the accepted time formula is:

$$\text{Expected time} = \frac{O + P + 4ML}{6}$$

For example assume that the three estimates for an activity are

Optimistic	11 days
Most likely	15 days
Pessimistic	18 days
Expected time =	$\frac{11 + 18 + 4(15)}{6}$
	= 14.8 days

- b) Use of time estimates. as three time estimates are converted to a single time estimate. There is no fundamental difference between the two methods as regards the basic time analysis of a network. However, on completion of the basic time analysis, projects with multiple time estimates can be further analyzed to give an estimate of the probability of completing the project by a scheduled date.
- c) Time units. Time estimates may be given in any unit, i.e. minutes , hours, days depending on the project. All times estimates within a project must be in the same units otherwise confusion is bound to occur.

Basic time analysis - critical path

- b) The critical path of a network gives the **shortest time in which the whole project can be completed**. It is the chain of activities with the longest duration times. There may be more than one critical path which may run through a dummy.

Earliest start times (EST) - Forward pass, Once the activities have been timed we can assess the total project time by calculating the ESTs for each activity. The EST is the earliest possible time at which a succeeding activity can start.

Assume the following network has been drawn and the activity times estimated in days.

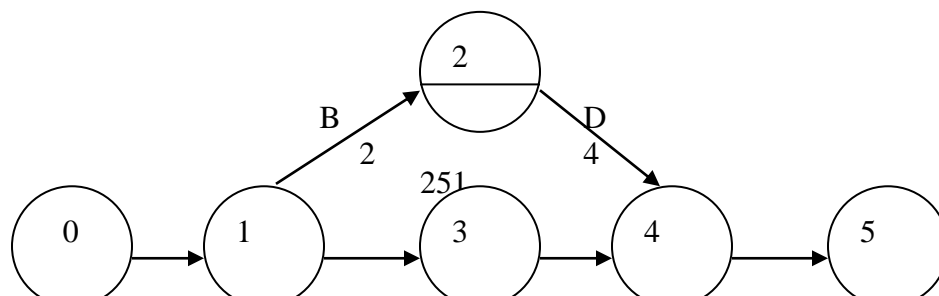

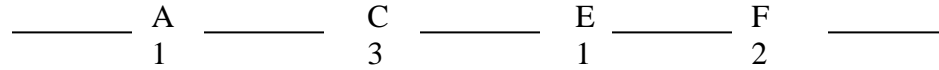

The ESTs can be inserted as follows.

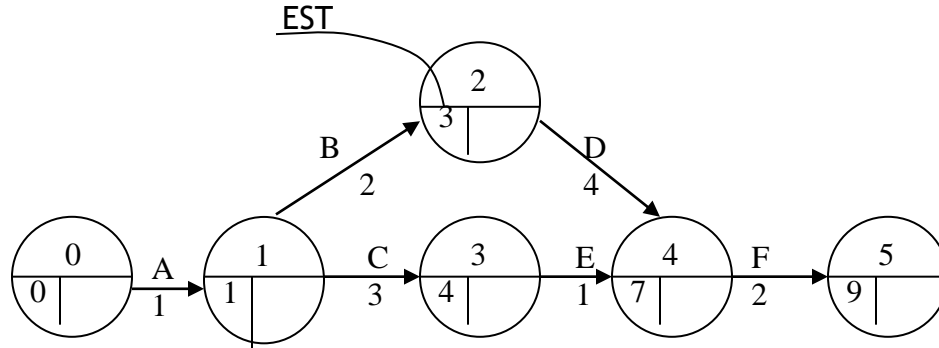

The method used to insert the ESTs is also known as the **forward pass**, this is obtained by;

$$\text{EST} = \text{The greater of [EST (tail event) + Activity duration]}$$

- Start from the start event giving it 0 values,
- For the rest of the events EST is obtained by summing the EST of the tail event and the activity duration
- Where two or more routes converge into an activity, calculate individual EST per route and then select the longest route (time)
- The EST of the finish event is the shortest time the whole project can be completed.

Latest Start Times (LST) - Backward pass. this is the latest possible time with which a preceding activity can finish without increasing the project duration. After this operation the critical path will be clearly defined.

From our example this is done as follows;

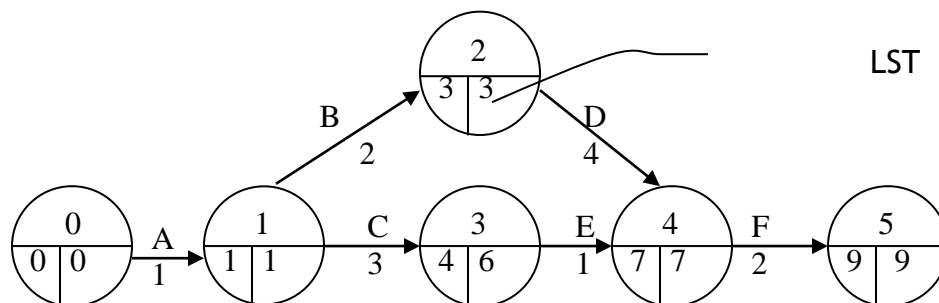

$$\text{LST} = \text{Lowest of [LST (head event) - activity duration]}$$

- Starting at the finish event, insert the LST (i.e. 9 for our example) ,and work backwards through the network.

- b) deduct each activity duration from the previously calculated LST (i.e. head LST).
- c) Where the tails of activities join an event, the lowest number is taken as the LST for that event

Critical path determination

Critical Path. . This is the chain of activities in a network with the longest duration Assessment of the resultant network shows that one path through the network (A, B, D, F) has EST's and LST's which are identical this is the critical path.

The critical path can be indicated on the network either by a different colour or by two small transverse lines across the arrows along the path, thus in our example we have;

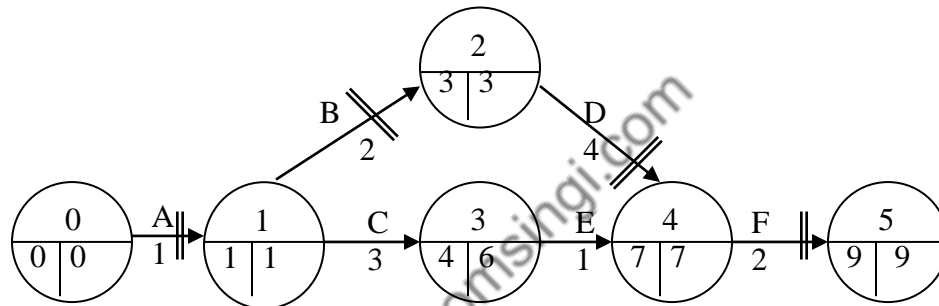

Activities along the critical path are vital activities which must be completed by their EST's/LST's otherwise the project will be delayed.

Non critical activities (in the example above, C and E) have spare time or *float* available. C and/ or E could take up to an additional 2 days in total without delaying the project duration. If it is required to reduce the overall project duration then the time of one or more of the activities on the critical path must be reduced perhaps by using more labour, or better equipment to reducing job times.

Float

Float or spare time can only be associated with activities which are non-critical. By definition, activities on the critical path cannot have float. There are three types of float, **Total Float**, **Free Float** and **Independent Float**. To illustrate these types of float we use the following example.

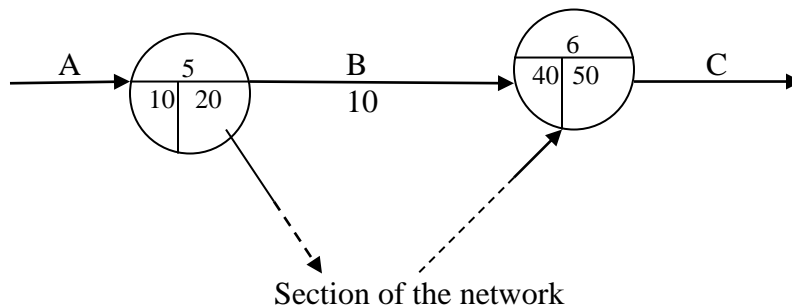

- a) Total float. Amount of time by which a path of activities could be delayed without affecting the overall project duration. The path in this example consists of one activity only i.e. B

Total Float = Latest Finish time (LFT) - Earliest Start time(EST) time - Activity Duration

$$\begin{aligned} \text{Total Float} &= 50 - 10 - 10 \\ &= \underline{30 \text{ days}} \end{aligned}$$

- b) Free float Amount of time an activity can be delayed without affecting the commencement of a subsequent activity at its earliest start time, but may affect float of a previous activity.

Free Float = Earliest Finish Time(EFT) - EST - Activity Duration

$$\begin{aligned} \text{Free Float} &= 40 - 10 - 10 \\ &= \underline{20 \text{ days}} \end{aligned}$$

- c) Independent float. Amount of time an activity can be delayed when all preceding activities are completed as late as possible and all succeeding activities commenced as early a possible. Independent float therefore does not affect the float of either preceding or subsequent activities.

Independent float = EFT- Latest Start time (EST) - Activity Duration

$$\begin{aligned} \text{Independent float} &= 40 - 20 - 10 \\ &= \underline{10 \text{ days}} \end{aligned}$$

Note:

- for examination purposes, float always refers to total float
- The total float can be calculated separately for each activity but it is often useful to find the total float over chains of non-critical activities *between critical events*

Example.

The following represents activities of a network.

Activity	Preceding Activity	Duration Days
A	-	4
B	A	7
C	A	5
D	A	6
E	B	2
F	C	3
G	E	5
H	B,F	11
I	G,H	7
J	C	4
K	D	3
L	I,J,K	4

Required:

- Draw the network diagram and find the critical path
- Calculate the floats of the network in question

Solution. (a)

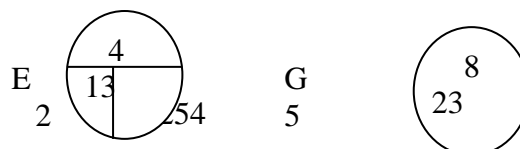

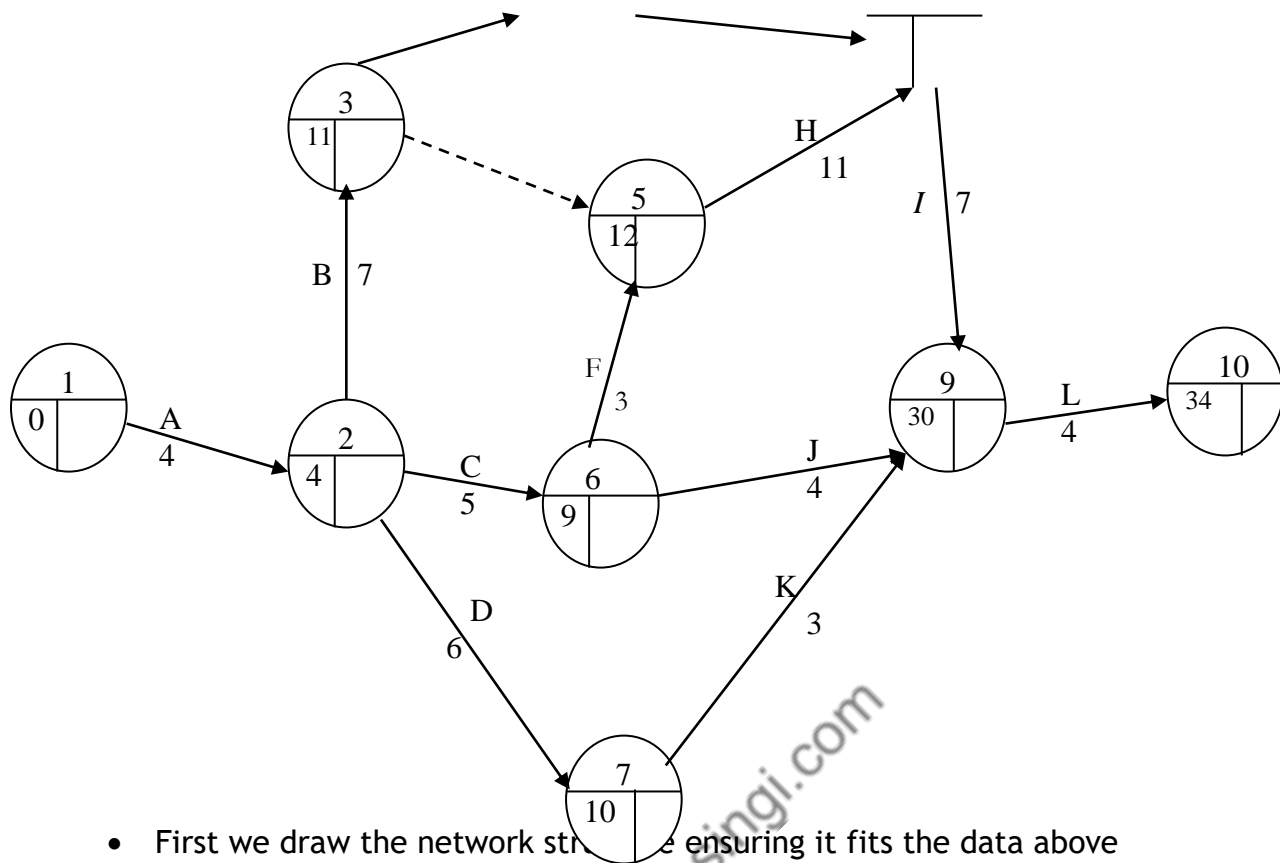

- First we draw the network structure ensuring it fits the data above
- We then label all activities from 1 to 12 and indicate activity duration
- Conduct a forward pass operation (to obtain the diagram above)
- Operate backward pass to establish the critical path, thus we have...

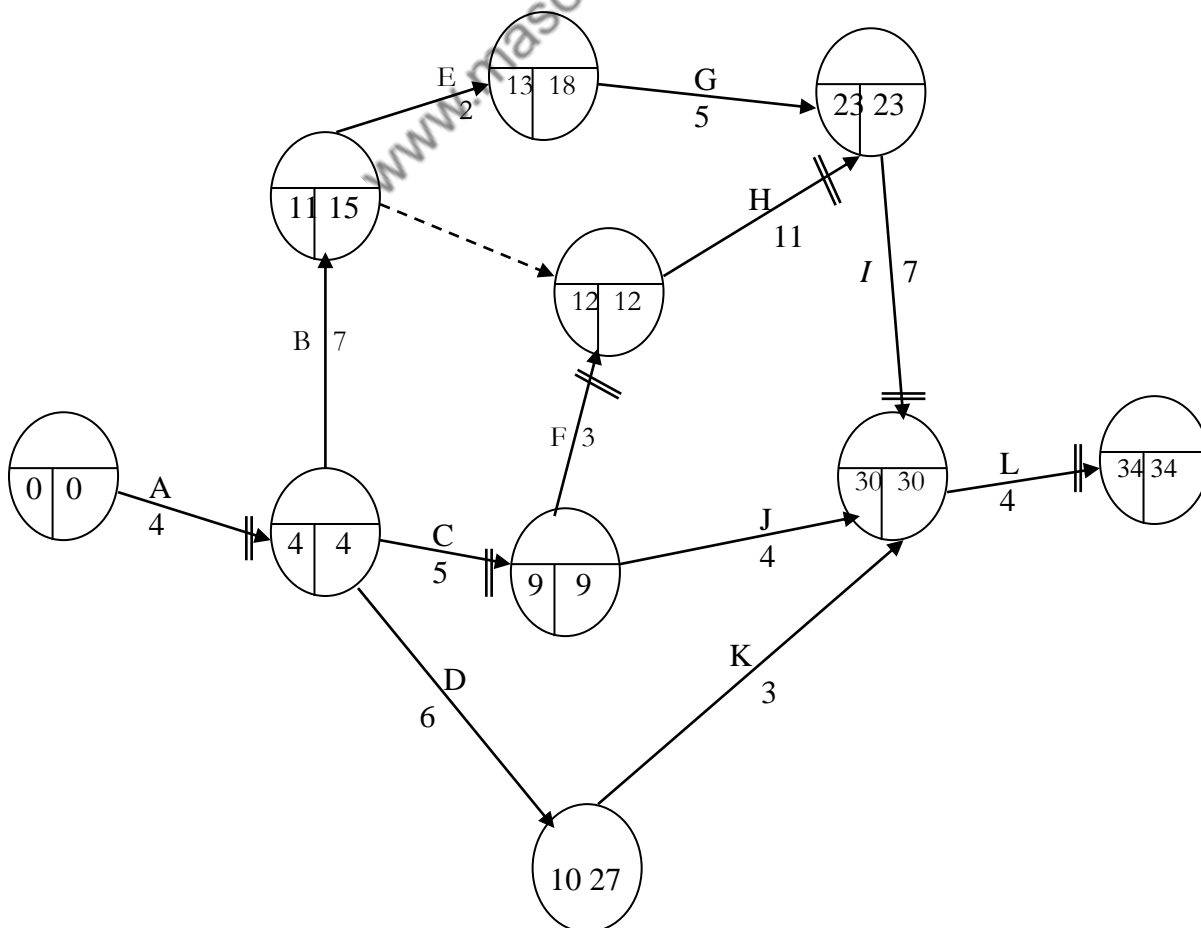

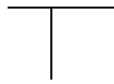

Therefore we get the critical path to be, A- C- F- H- I- L

b) The floats of the network,

Activity	EST	LST	EFT	LFT	Activity Duration	Total Float LFT - EST - D	Free Float EFT - EST - D	Independent Float EFT - LST - D
*A	0	0	4	4	4	-	-	-
B	4	4	11	15	7	4	-	-
*C	4	4	9	9	5	-	-	-
D	4	4	10	22	6	12	-	-
E	11	15	13	21	2	8	-	-
*F	9	9	15	15	3	-	-	-
G	13	21	23	23	5	5	5	-
*H	12	12	23	23	11	-	-	-
*I	23	23	30	30	7	-	-	-
J	9	9	30	30	4	17	17	17
K	10	22	30	30	3	17	17	5
*L	30	30	34	34	4	-	-	-

The total float on the non-critical chains are;

Non-critical chain	Time required (sum of duration)	Time available (LFT of last activity - EST of 1 st activity)	Total Float over chain
B, E, G	14	19	5
B, Dummy	7	8	1
D, K	9	26	17
J	4	21	17

Slack

This is the difference between the EST and LST for each event. Strictly it does not apply to activities but on occasions the terms are confused in examination questions and unless the context makes it abundantly clear that event slack is required, it is likely that some form of activity float is required. Events on the critical path have zero slack.

APPLICATIONS

Cost Scheduling

This is done by calculating the cost of various project durations, cost analysis seeks to find the cheapest way of reducing the overall cost duration of a project by increasing labour hours, equipment e.t.c.

Terminologies

Normal cost. The costs associated with a normal time estimate for an activity. Often the normal time estimate is set at the point where resources

(labour, equipment, etc.) are used in the most efficient manner.

Crash cost. The costs associated with the minimum possible time for an activity. Crash costs, because of extra wages, overtime premiums, extra facility costs are always higher than normal costs.

Crash time. The minimum possible time that an activity is planned to take. . The minimum time is invariably brought about by the application of extra resources, e.g. more labour or machinery.

Cost slope. This is the average cost of shortening an activity by one time unit (day, week, month as appropriate). The cost slope is generally assumed to be linear and is calculated as follows:

$$\text{Cost slope} = \frac{\text{Crash cost} - \text{Normal cost}}{\text{Normal time} - \text{Crash time}}$$

Example

A project has the following activities and costs. You are required to prepare the least cost schedules for all possible durations from *normal time - normal cost* to *crash time - crash cost*.

www.masomomsingi.com

Activity	Preceding Activity	Duration days	Crash time	Cost (Shs).	Crash cost	Cost slope
A	-	4	3	360	420	60
B	-	8	5	300	510	70
C	A	5	3	170	270	50
D	A	9	7	220	300	40
E	B,C	5	3	200	360	80

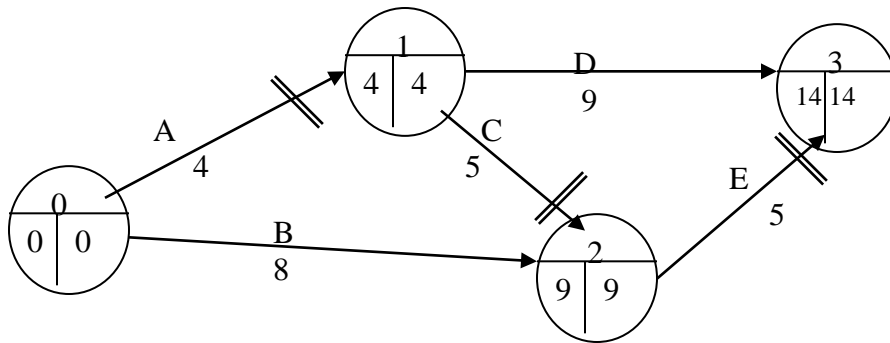

Project duration and costs

- (a) Normal duration = 14 days
 Critical path = A,C,E
 Project cost (cost of all activities in normal time) = Shs. 1,250.
- (b) Reduce by 1 day the activity on the critical path with the lowest cost slope. Thus we reduce C at extra cost of Shs. 50.

Now

Project duration = 13 days
 Project cost = Shs. 1,300

Note: that all activities are now critical.

- (c) Further reducing the critical path by 1 day will require that more than one activity is affected because there exist several critical paths.

Reduce by 1 day	Extra cost	Activities critical
A and B	$60 + 70 = 130$	All
D and E	$40 + 80 = 120$	All
B, C and D	$70 + 50 + 40 = 160$	All
A and E	$60 + 80 = 140$	A, D, B, E

From this we realize that reducing D and E is the cheapest.

However closer examination of the fourth alternative reveals that C is now non-critical and has 1 day float. Since we earlier reduced C for Shs. 50, if we reduce A and E and increase C by a day which will save Shs. 50.

Then the net cost for 12 day duration = 1,300 + (140 - 50) = 1,390.

The network becomes.....

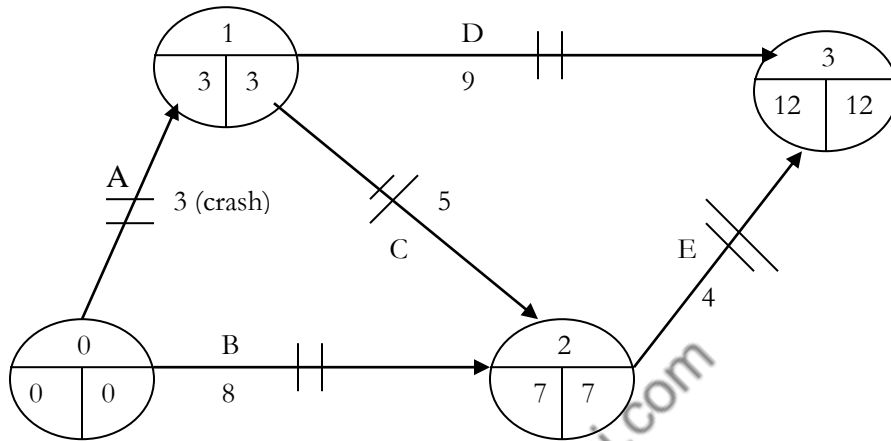

- (d) Next we reduce D & E
 Project duration = 11 days
 Project cost = 1,510
 Critical activities = All

- (e) Final reduction possible is by reducing B, C & D for Shs. 160 the network then becomes.

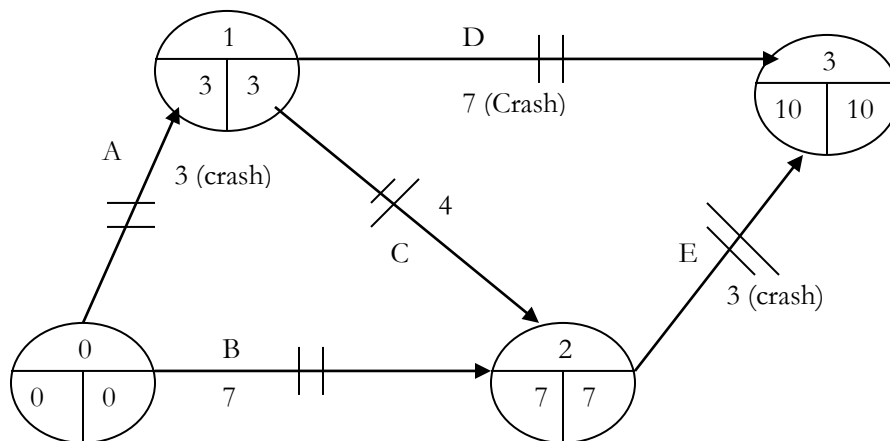

Duration = 10 days

Cost = Shs. 1,670
 Critical activities = All.

Note: only critical activities affect project duration.
 : Always look for a possibility of increasing the duration of a
 previously
 Crashed activity.

Scheduling Resources and Gantt Chart

Apart from time, cost network analysis also help in controlling and planning of resources.

Example

A project has the following activity durations and resource requirements.

Activity	Preceding activity	Duration (days)	Resource requirement (man power)
A	-	6	3
B	-	3	2
C	-	2	2
D	C	2	1
E	B	1	2
F	D	1	1

Required

- What is the networks critical path
- Draw a gantt chart diagram indicating activity times, using their estimate.
- Show resource requirement on a day to day basis assuming all events commence at their estimates.
- Assuming that only six employees are available, how will the activities be planned for?

Solution

i)

Activities	Duration	EST	LST	Man power
A	6	0	0	3
B	3	0	0	2
C	2	0	0	2
D	2	2	3	1
E	1	3	5	2
F	1	4	5	1

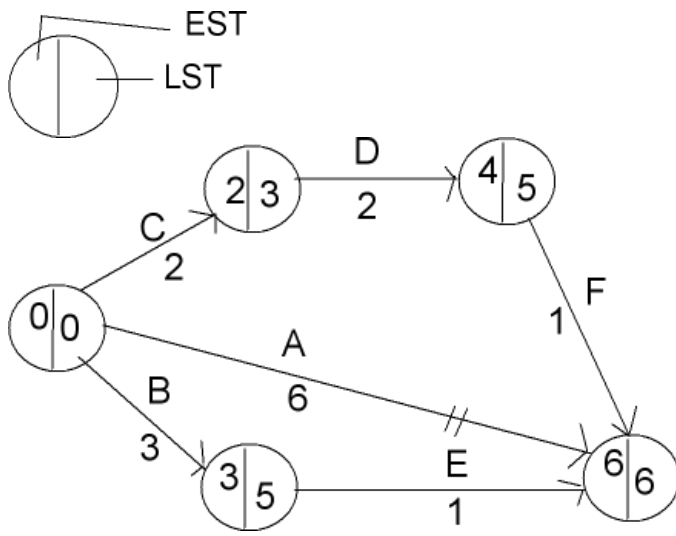

www.masomomsingi.com

- ii) A gantt chart or a bar chart. This is a diagram indicating a resource scaled network.

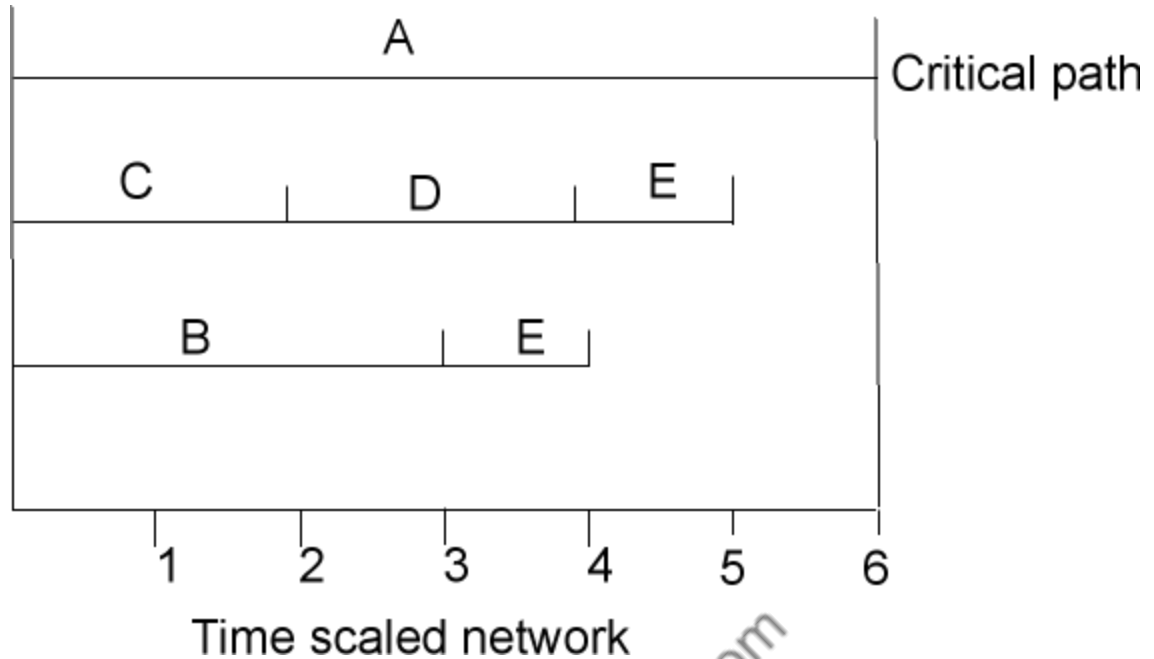

- iii) Resource requirements on a day to day basis.

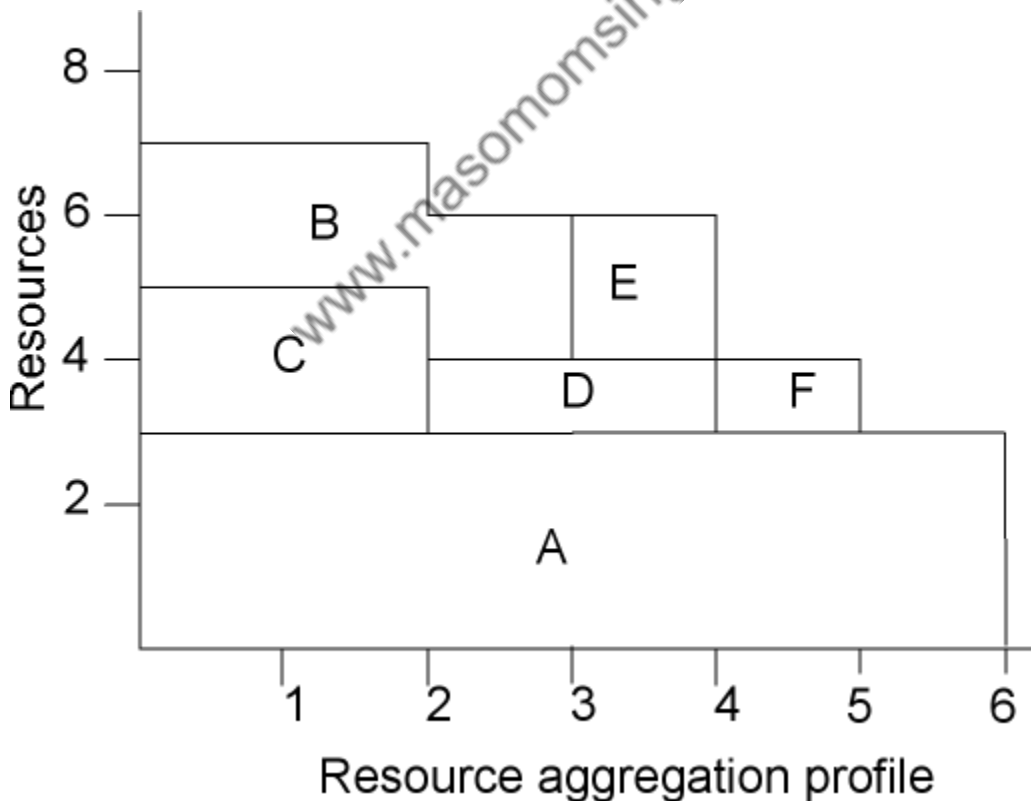

- iv) When on 6 manpower resources are available then we adjust the activities to accommodate this and still end at the given critical time duration i.e.

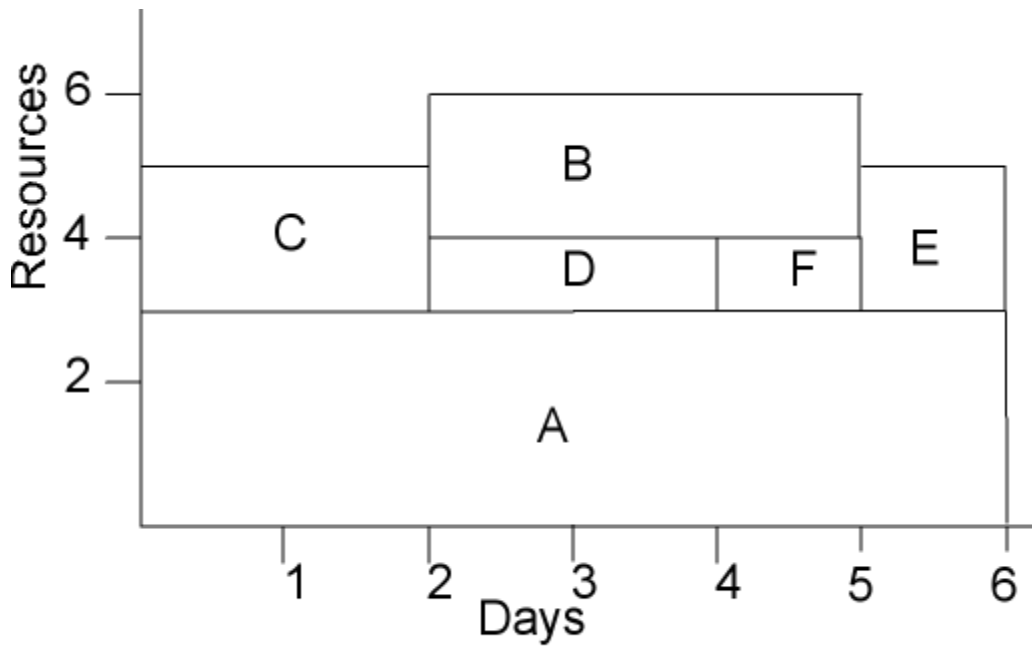

Smoothened Resource requirements

Node Networks

This network also known as a procedure diagram is represented with the same information as a network diagram.

Its characteristics are;

- i) Activities are shown in boxes instead of arrows
- ii) Events are not represented.
- iii) The arrows linking boxes indicate the sequence precedence of activities.
- iv) Dummies aren't necessary.

E.g.

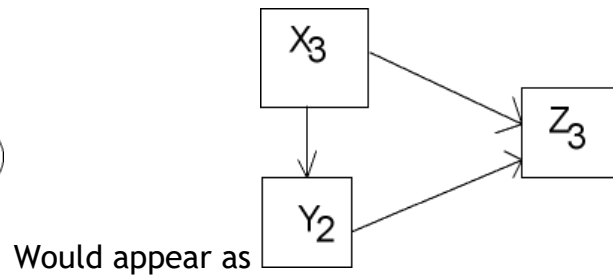
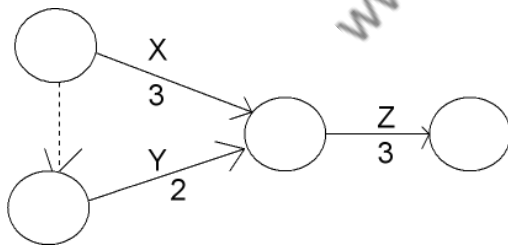

A full activity node network is represented as;

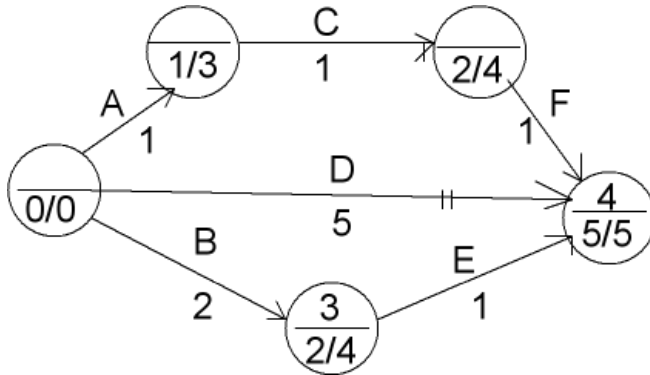

This is represented as;

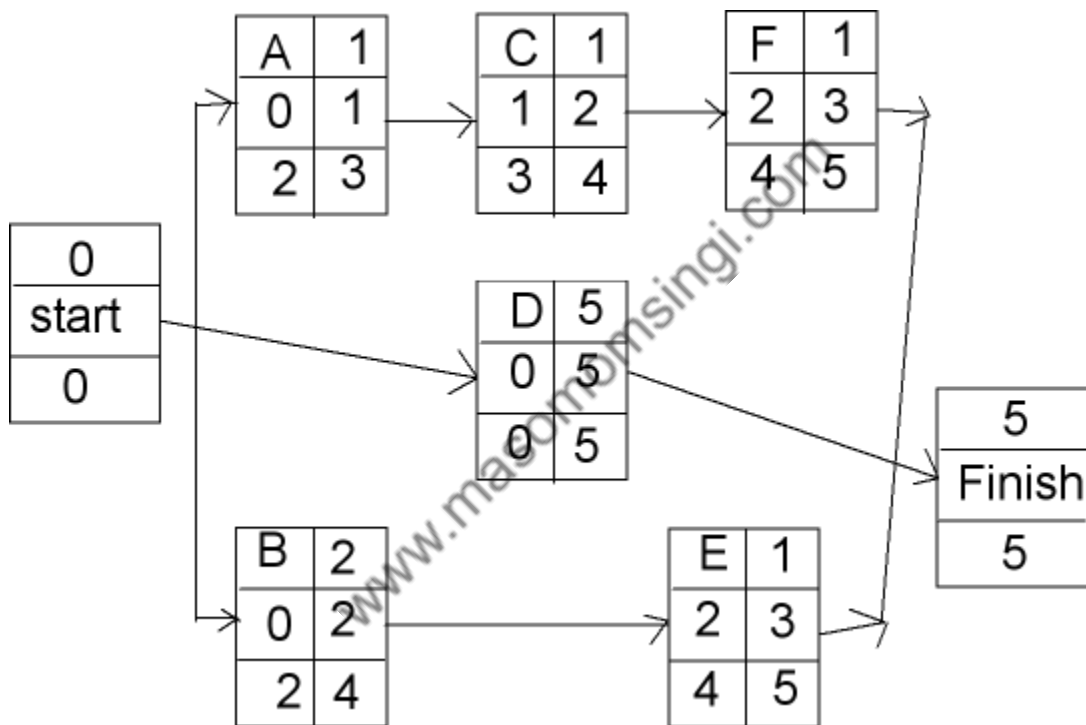

Note:

- i) EST and LST are calculated by the same process we learnt earlier.
- ii) EFT and LFT are calculated by adding the activity time duration to EST and LST respectively.
- iii) Critical path is similarly identified by identifying equal EST and LST throughout the path.

LESSON 8 REINFORCING QUESTIONS

QUESTION ONE

Regal Investments has just received instructions from a client to invest in two shares; one an airline share, the other an insurance share. The total maximum appreciation in share value over the next year is to be maximized subject to the following restrictions:

- the total investment shall not exceed Sh.100,000
- at most Sh.40,000 is to be invested in the insurance shares
- quarterly dividends must total at least Sh.2,600

The airline share is currently selling for Sh.40 per share and its quarterly dividend is Sh.1 per share. The insurance share is currently selling for Sh.50 per share and the quarterly dividend is Sh.1.50 per share. Regal's analysts predict that over the next year, the value of the airline share will increase by Sh.2 per share and the value of the insurance share will increase by Sh.3 per share.

A computer software provided the following part solution output:

Objective Function Value = 5,400

	Variable	Number	Reduced cost
Airline shares	1,500	0.000	
Insurance shares	800	0.000	
Constraint	Slack/Surplus		Dual prices
Total investment		0.000	0.050
Investment in insurance		0.000	0.010
Dividends		100.000	0.000

Objective Coefficient Ranges

Variable	Lower limit	Current value	Upper limit
Airline share	2.500	3.000	No upper limit
Insurance share	0.000	2.000	2.400

Right-hand Side Ranges

Constraint	Lower limit	Current value	Upper limit
Total investment	96,000.00	100,000	No upper limit
Investment in insurance	20,000.00	40,000	100,000.00
Dividends	No lower limit	2,600	2,700.00

Required:

- Formulate the above problem.
- Explain what reduced cost and dual prices columns above mean.
- How should the client's money be invested to satisfy the restrictions?
- Suppose Regal's estimate of the airline shares appreciation is an error, within what limits must the actual appreciation lie for the answer in (c) above to remain optimal?

(Q 6 Dec

2001)

QUESTION TWO

- A baker makes two products; large loaves and small round loaves. He can sell up to 280 of the large loaves and up to 400 small round loaves per day. Each large loaf occupies 0.01m^3 of shelf space, each small loaf occupies 0.008m^3 of space, and there is 4m^3 of shelf space available. There are 8 hours available each night for baking, and he can produce large loaves at the rate of 40 per hour, and small loaves at the rate of 80 per hour. The profit on each large loaf is Sh.5.00 and Sh.3.00 profit on the small round loaf.

Required:

In order to maximize profits, how many large and small round loaves should he produce?

- Summarize the procedure for solving the kind of quantitative technique you have used to solve part (a) above.

(Q 6 June

2001)

QUESTION THREE

- A small company will be introducing a new line of lightweight bicycle frames to be made from special aluminium alloy and steel alloy. The frames will be produced in two models, deluxe and professional. The anticipated unit profits are currently Sh.1,000 for a deluxe frame and Sh.1,500 for a professional frame. The number of kilogrammes of each alloy

needed per frame is summarized in the table below. A supplier delivers 100 kilogrammes of the aluminium alloy and 80 kilogrammes of the steel alloy weekly.

	Aluminium alloy	Steel alloy
Deluxe	2	3
Professional	4	2

Required:

- i) Determine the optimal weekly production schedule.
 - ii) Within what limits must the unit profits lie for each of the frames for this solution to remain optimal?
- b) Explain the limitations of the technique you have used to solve part (a) above.

(Q 6 Dec 2000)

QUESTION FOUR

- a) Define the following terms as used in linear programming:
 - i) Feasible solution
 - ii) Transportation problem
 - iii) Assignment problem
- b) The TamuTamu products company ltd is considering an expansion into five new sales districts. The company has been able to hire four new experienced salespersons. Upo analysing the new salesperson’s past experience in combination with a personality test which was given to them, the company assigned a rating to each of the salespersons for each of the districts .These ratings are as follows:

c)

		Districts				
		1	2	3	4	5
Salespersons	A	92	90	94	91	83
	B	84	88	96	82	81
	C	90	90	93	86	93
	D	78	94	89	84	88

The company knows that with four salespersons, only four of the five potential districts can be covered.

Required:

- i) The four districts that the salespersons should be assigned to in order to maximize the total of the ratings
- ii) Maximum total rating.

(Q 6 June 2002)

QUESTION FIVE

- a) Explain the value of sensitivity analysis in linear programming problems and show how dual values are useful in identifying the price worth paying to relax constraints.
- b) J.A Computers is a small manufacturer of personal computers. It concentrates on production of three models- a Desktop 386, a Desktop 286, and a Laptop 486, each containing one CPU Chip. Due to its limited assembly facilities JA Computers are unable to produce more than 500 desktop models or more than 250 Laptop models per month. It has one hundred and twenty 80386 chips (these are used in Desktop-386) and four hundred 80286 chips (used in desktop 286 and Laptop 486) for the month. The Desktop 386 model requires five hours of production time, the Desktop 286 model requires four hours of production time, and the Laptop 486 requires three hours of production time. J.A Computers have 2000 hours of production time available for the coming month. The company estimates that the profit on Desktop 386 is Sh. 5,000. for a desktop 286 the profit is Sh.3,400 and Sh.3,000 profit for a laptop 486.

Required:

Formulate this problem as a profit maximization problem and mention the basic assumptions that are inherent in such models.

- c) An extract of the output from a computer package for this problem is given below:

Output solution

$$X_1=120, X_2 = 200, X_3 = 200$$

Dual values Constraints 3 150

 Constraints 4 90

 Constraints 5 20

Sensitivity analysis of objective function coefficients:

Variable	Lower limit	Original value	Upper limit
X_1	100	250	No limit
X_2	150	170	200
X_3	127.5	150	170

Sensitivity analysis on R.H.S ranges.

Constraints	Lower limit	Original value	Upper limit
1	320	500	No limit
2	200	250	No limit
3	80	120	130
4	350	400	412.5
5	1950	2000	2180

X_1 = Monthly production level for Desktop 386.
 X_2 = Monthly production level for Desktop 286.
 X_3 = Monthly production level for Laptop 486.

Required:

- i) Interpret the output clearly, including optimum product mix, monthly profit, unused resources and dual values
- ii) Explain the purpose of upper limits and lower limits for the variables X_1, X_2, X_3 and constraints 1 to 5.
- iii) Calculate the increase in profit if the company is able to produce a further 10 CPU 80386 chips. (Q7 July 2000 Pilot paper)

QUESTION SIX

Preface Retailers is a high-technology retailer and mail order business. In order to improve its process the company decides to install a new microcomputer system to manage its entire operation (i.e. payroll, accounts, inventory).

Terminals for each of its many stores will be networked for fast, dependable service. The specific activities that Preface will need to accomplish before the system is up and running are listed below. The table also includes the necessary increased staffing to undertake the project.

Activity	Preceding Activities	Duration (Days)	Increase d Staff
A. Build insulated enclosure	-	4	1
B. Decide on computer system	-	1	3
C. Electrical wiring of room	A	3	2
D. Order and collect computer	B	2	1
E. Install air conditioning	A	4	2
F. Install computer	D, E	2	2
G. Staff testing	B	5	1
H. Install software	C, F	2	1
I. Staff training	G, H	3	1

Required:

- a) Draw a network diagram for the project and determine the critical path and its duration.
- b) Assuming that all activities start as soon as possible, draw a progress chart for the project, showing the times at which each activity takes place and the manpower requirements.
- c) The union has decided that any staff employed on the project must be paid for the duration of the project whether they work or not, at a rate of £500 per day.

Assuming that the same staff is employed on the different activities, determine the work schedule that will minimise labour costs though not necessarily the project time. What is the cost associated with this schedule?

Comment on the validity of the assumption.

www.masomomsingi.com